

## Pint O Shine's 6 Gallon Pot Still Design and Template

*Upsized to 12 Gallon Still on a 36"x56" sheet*



## ***Warning!***

I assume no responsibility to the use or accuracy of this document. It is intended for educational purposes only. I maintain all copyright ownership for all my original work. This document may be used freely and circulated freely but may not be sold for profit, or included in any other book or website for profit. This specifically applies to web sites that are for profit only and contain mostly advertising.

***Sherman Owen ©2007***

***Upsizing to 12 gallons, and new layout, by The Husker Distiller.***

# Traditional Moonshine Stills

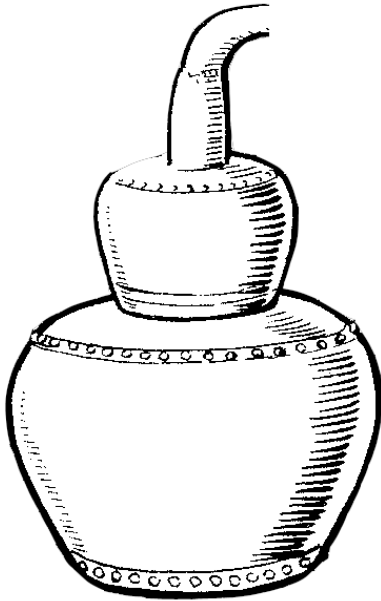

Turnip



Half Turnip



Upright Pot Still

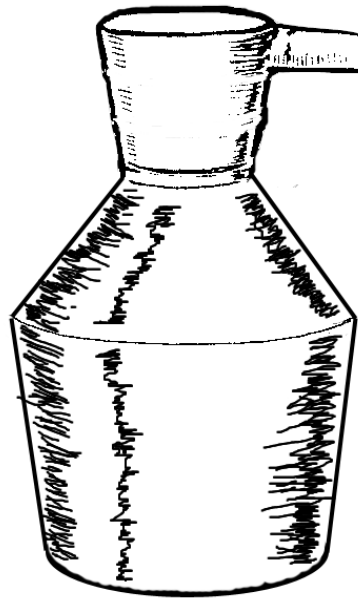

Kentucky Still

## **Design Considerations**

When I decided to design the 6 gallon, copper pot still, I had few criteria in mind. First I wanted to fit the whole thing on a single half sheet of copper. A half sheet is usually 3' x 4'. This size sheet is readily available by internet order. I have limited tools and limited skills at metal working so I decided to imitate a construction style found in the book: "More Mountain Spirits" by Joseph Earl Dabney.

I selected the Kentucky Still as my design. I research standard sheet metal layout patterns for cones thinking I could use one of those to create my templates. I was wrong in thinking the existing layout guidelines were accurate enough to make even cone sections. I later learned that the shape I was in need of to construct the still was actually called a frustum. A frustum is a right cone in which the top has been cut off parallel to the base of the cone.

I derived a series of calculations to allow me to lay out the flattened frustum in a drawing program to allow me to generate templates.

Another design criteria was that I wanted a small stove top model to be able to run experimental 2 to 5 gallon batches.

*The upsizing was done by Husker distiller. 6 gallon stills serve a purpose, but larger ones also serve their own purpose. The copper sheet distributor I found on the web, provides reasonable shipping charges for sheets, up to 56". Thus this still was made to fit as large as possible on a 36"x56" sheet. 12 gallons was able to be squeezed on to that sheet, but the Flake stand did not fit. A diagram of how to make a 5 gallon flake stand on an extra 17"x36" sheet has been included in this document. The flake stand would not need to be made out of the thick 0.032 sheet. 0.025 would suffice.*

### **Software used to create this document**

I used Cadopia's free version of IntelliCAD 2000 for Windows. I acquired this program whenever they were still giving it away for free. It is a very nice AutoCAD v14 compatible program with All versions of windows I have used over the years. It has all the standard AutoCAD functionality except for 3d rendering.

Of course Open Office Word Processor was used for the assembling the textual parts of the document.

I use Photoshop v6.0, Paint, and ACD Systems ACDSee v3.1 to create and modify graphics other than AutoCAD drawings.

The PDF file was generate using PDFCreator which is a free Open source PDF printer driver and spooler with great functionality for assembling documents from lots of different sources. I had difficulty running this in Vista but I figured out a work around.

***Thank You for your interest and I hope it is useful for the educational purposes in which it was intended.***

# Still Frustum Design

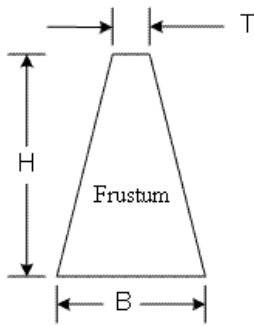

The volume of the frustum is calculated using the following calculation.

$$R = B/2 \quad r = T/2$$

$$V = \frac{H\pi}{3} (R^2 + Rr + r^2)$$

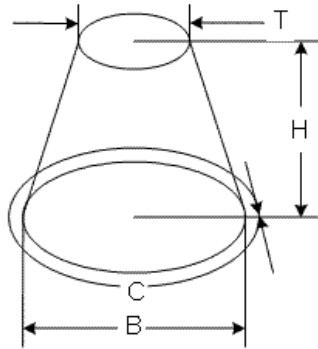
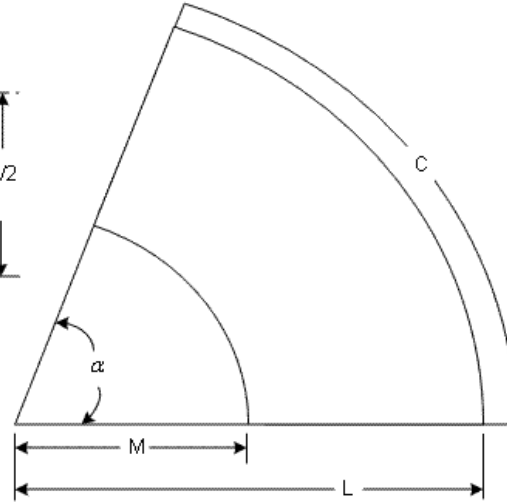
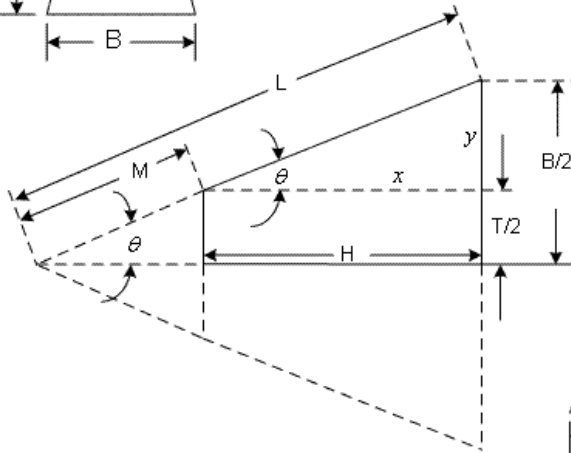

$$\tan(\theta) = \frac{y}{x} = \frac{B/2 - T/2}{H}$$

$$\theta = \tan^{-1}\left(\frac{B/2 - T/2}{H}\right) \quad L = \frac{B/2}{\sin(\theta)} \quad M = \frac{T/2}{\sin(\theta)}$$

$\omega$ (radians)

$$\text{arc} = r\omega$$

$$C = B\pi$$

$$\text{arc} = C$$

$$r\omega = B\pi$$

$$\omega = \frac{B\pi}{r}$$

$$\text{degrees} = \frac{180\text{radians}}{\pi}$$

$$\alpha = \frac{180B\pi}{r\pi}$$

$$r = L$$

$$\alpha = \frac{180B}{L}$$

## Calculation Results

I was aiming at a 6 Gallon pot for this project and I calculated on that was 5.99 gallons to the bottom of the collar. These are the calculation results.

	Bottom	Top	Cap	Lyne Arm
B(in)	13.000	13.000	7.250	3.000
H(in)	9.000	6.000	6.000	15.000
T(in)	10.000	6.000	5.750	1.000
$\theta$ (radians)	0.165	0.528	0.124	0.067
$\alpha$ (degrees)	59.184	181.394	44.653	23.947
L(in)	39.538	12.900	29.226	22.550
M(in)	30.414	5.954	23.179	7.517
			Total	
Volume (gallons)	4.069790483	1.9243955	Volume(g)	5.99

	Bottom	Top	Cap	Lyne Arm
B(mm)	330.200	330.200	184.150	76.200
H(mm)	228.600	152.400	152.400	381.000
T(mm)	254.000	152.400	146.050	25.400
$\theta$ (radians)	0.165	0.528	0.124	0.067
$\alpha$ (degrees)	59.184	181.394	44.653	23.947
L(mm)	1004.264	327.663	742.332	572.769
M(mm)	772.511	151.229	588.746	190.923
			Total	
Volume (liters)	15.40415698	7.283836967	Volume(L)	22.69

These are all the units I used to generate the drawings.

**(NOTE the 12 gallon, is simply the 6 gallon still scaled up by 1.26x within the CAD program. That was the “magic” number that upsized to 12 gallons. The 12 gallon still parts had to be repositioned to make them fit on the 36x56, and the CAD program was also able to handle that job, and also to plot the 32 template pages.)**

## Circle Patterns and Assembly

The circles I cut from these templates have a 1/2” extension. Whenever I built my stainless steel model, I learned to hammer down the lip around the circle to create a pan. With stainless steel this is a arduous task because of its hardness. I have not done it yet but I intend to turn the lips on the circles the same way. I am hoping that the circles will be nice, flat pans that I can easily rivet to the frustums and solder.

If I am not able to create these nice hammered edges, I will cut tabs from the extension and bend them with pliers. This is the method I used for the stainless pot still.

## Pattern Printing

The end of the document contains a 32 page template that can be printed, assembled and used for a pattern to cut around like a dressmaker’s pattern. This is the method I use to build the stainless model. When printing the pattern, make sure to set Adobe Acrobat to print actual size. You may try a page or two to test the scale. The scale of the grid is in inches. One square should be 1”x1”. I have been having good luck with most of the printers I have used under the windows operating system.

When assembling the pattern, I cut off the top margin of the page to the solid line and the left margin to the solid line and taper the pages starting top left and going to bottom right. The easiest way is to assemble one page at a time to the template. All parts are marked with the page number and the edges are marked with the adjoining pages.

### ***Additional Resource Information***

Pint-o-Shine has put together a wonderful 6 gallon still template. That was the template (and the CAD .dwg drawings) which was used by Husker distiller, through a gracious sharing of information from Pint-o. The original 6 gallon pdf file can be located at:

<http://www.artisan-distiller.org/designs/>

Pint-o has also put some WONDERFUL videos together which show some step by step issues in building this paper template, and also in WORKING the sheet copper. These videos are WELL WORTH watching several times, before undertaking the building of this still. These videos are on you-tube at:

[http://www.youtube.com/view\\_play\\_list?p=DADEC413C1D46214](http://www.youtube.com/view_play_list?p=DADEC413C1D46214)

The discussion thread on the HomeDistiller forums can be read at:

<http://www.homedistiller.org/forums/viewtopic.php?t=5595>

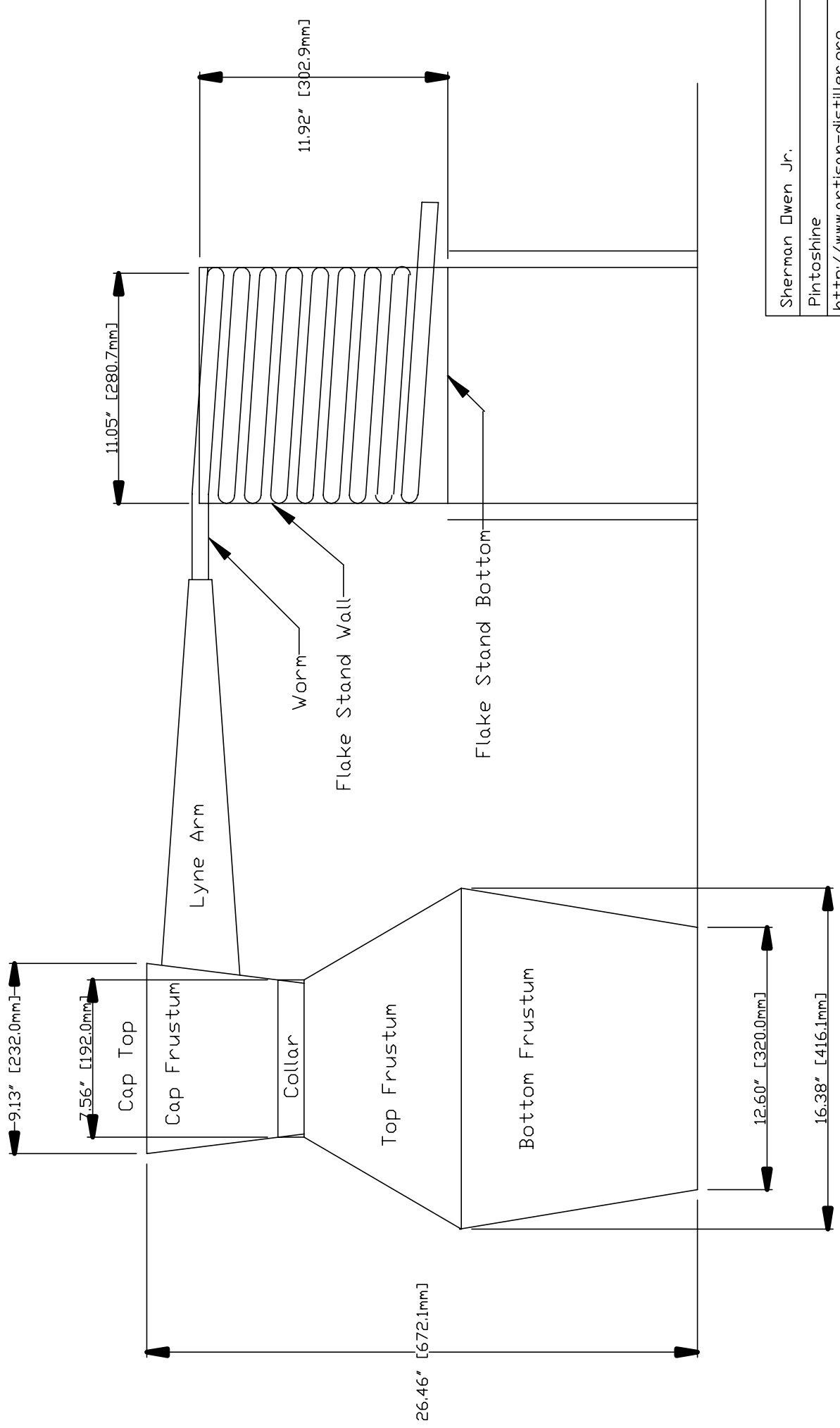

Sherman Owen Jr.
Pintoshine
<a href="http://www.artisan-distiller.org">http://www.artisan-distiller.org</a>
Suggested Layout of Pattern
12 Gallon Copper Pot
12 Gallon upsized by Husker



# Top Frustum

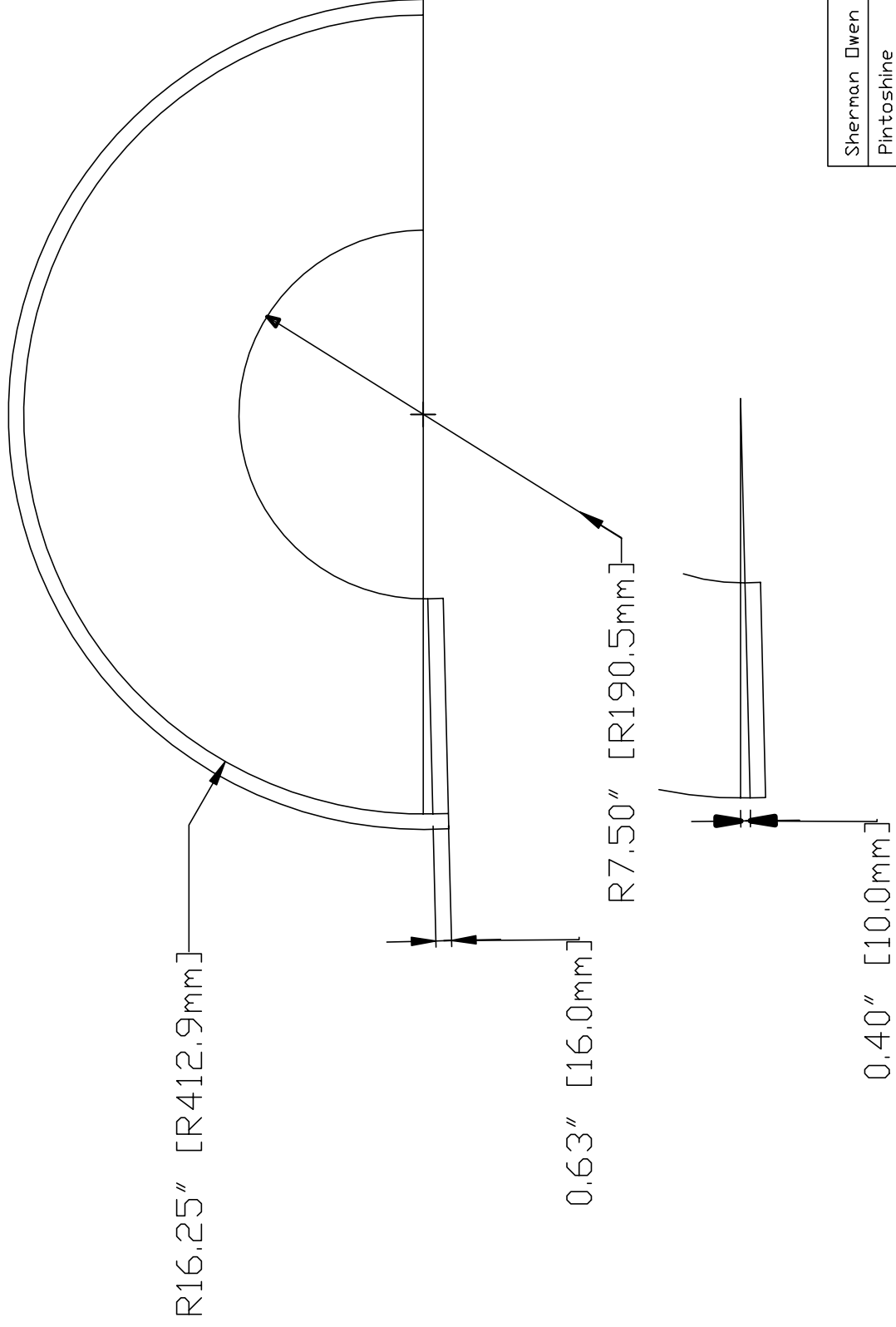

Sherman Owen Jr.
Pintoshine
<a href="http://www.artisan-distiller.org">http://www.artisan-distiller.org</a>
Top Frustum
12 Gallon Copper Pot
12 Gallon upsized by Husker

# Bottom Frustum

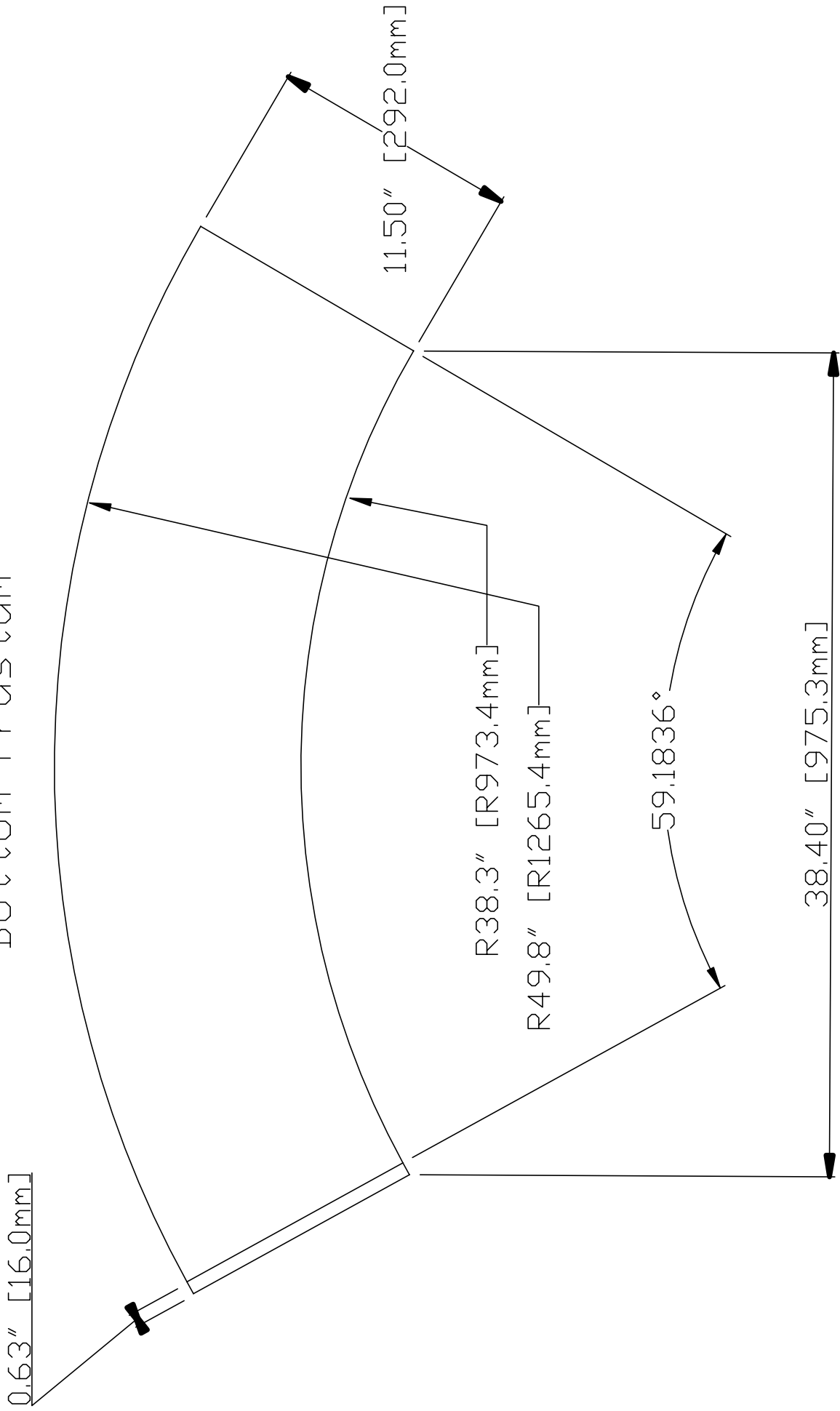

Sherman Owen Jr.
Pintoshine
<a href="http://www.artisan-distiller.org">http://www.artisan-distiller.org</a>
Bottom Frustum
12 Gallon Copper Pot
12 Gallon upsized by Husker

Collar

3.0" [75.2mm]

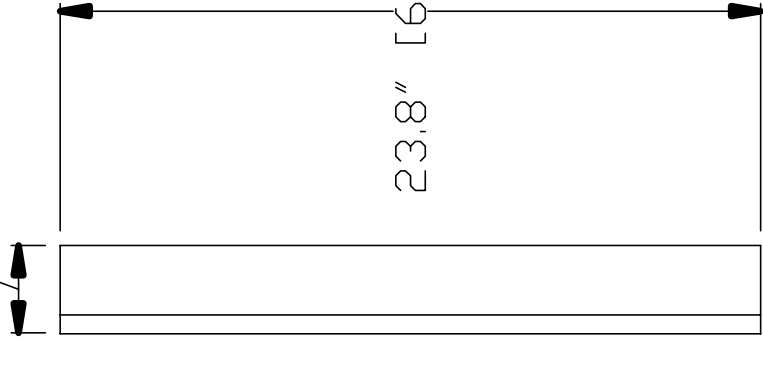

23.8" [603.3mm]

0.63" [16.1mm]

Bottom

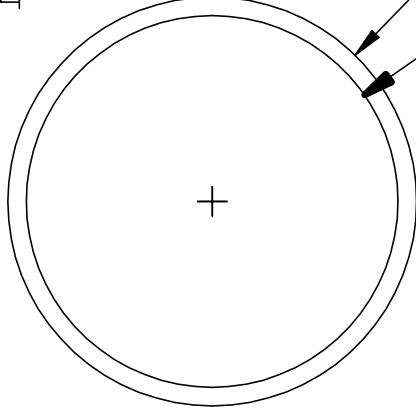

R6.30" [R160.0mm]

R6.93" [R176.0mm]

Top

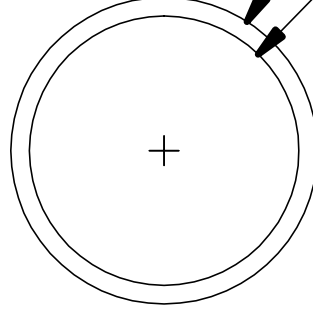

R4.57" [R116.0mm]

R5.20" [R132.0mm]

Sherman Owen Jr.

Pintoshine

<http://www.artisan-distiller.org>

Top, Bottom, Collar

12 Gallon Copper Pot

12 Gallon upsized by Husker

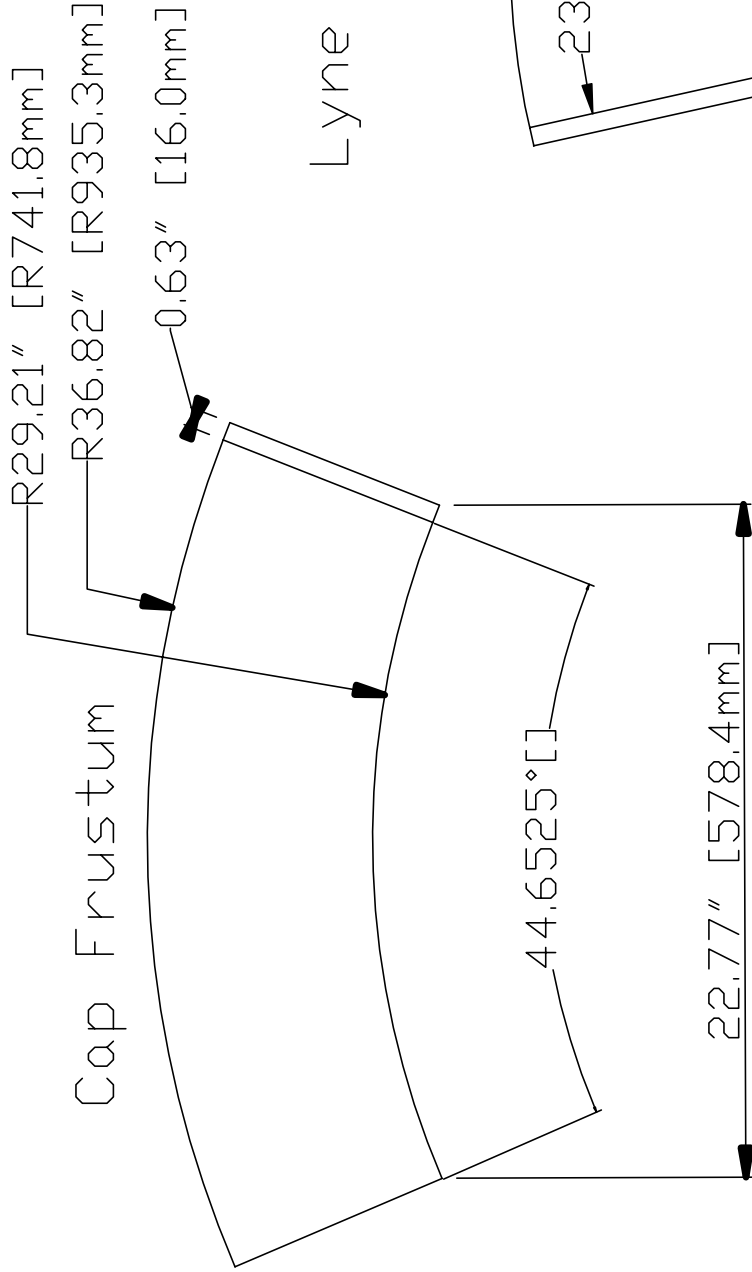

Lyne Arm

R9.5" [R240.6mm]  
R28.4" [R721.7mm]

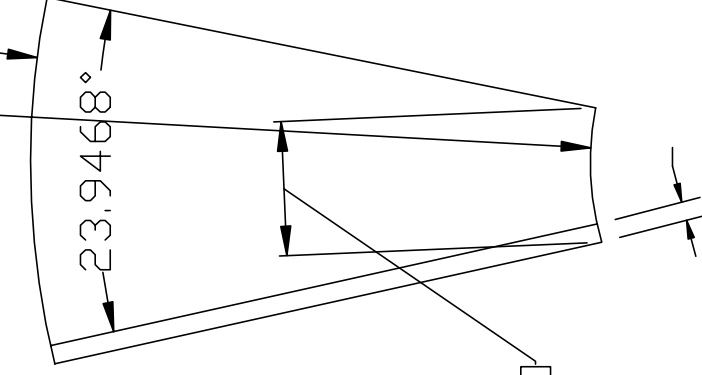

+

0.5" [12.7mm]

+

Sherman Owen Jr.

Pintoshine

<http://www.artisan-distiller.org>

Cap Frustum, Lyne Arm

12 Gallon Copper Pot

12 Gallon upsized by Husker

**NOTE Flake stand  
on separate sheet,  
18"x36" 0.025 copper**

Flake Stand Wall  
*(after the 2 pieces are joined)*

**Flake base  
is 2 12x18"  
pieces  
riveted  
together to  
get a 12"  
tall tube**

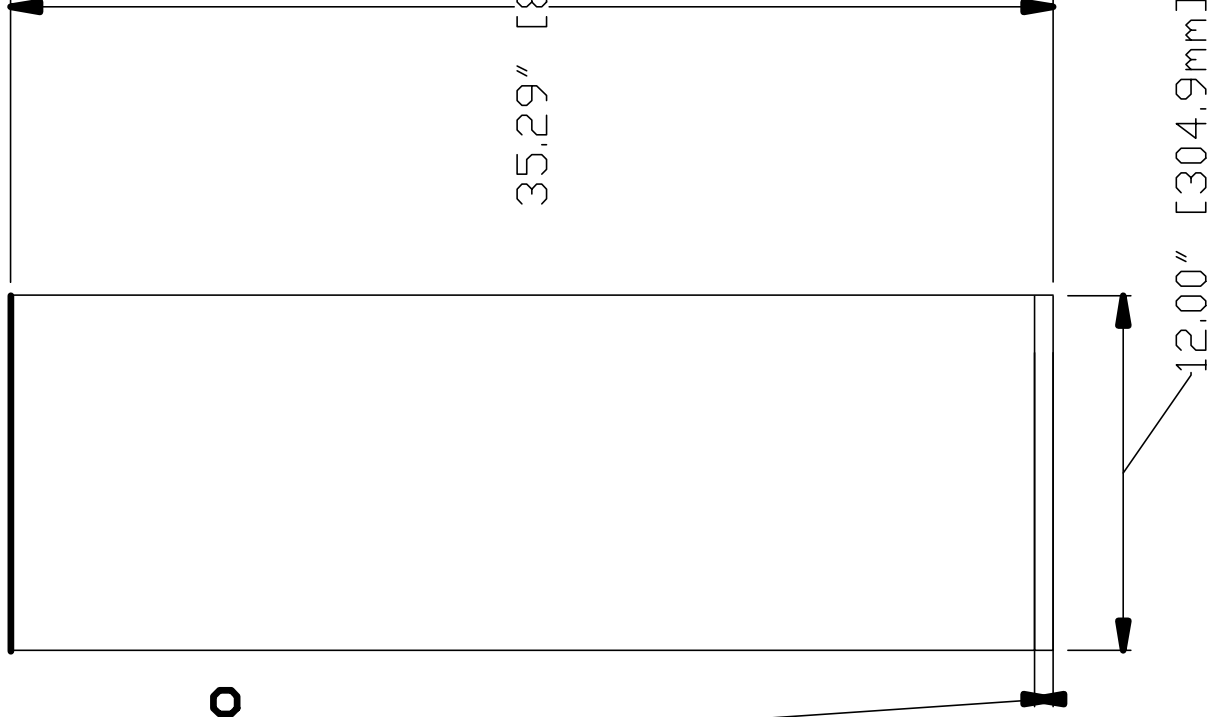

Flake Stand Bottom

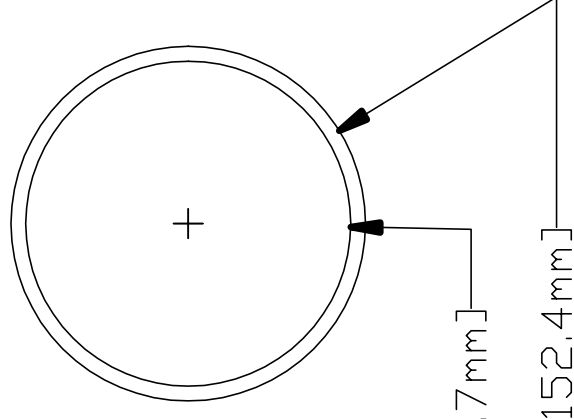

Sherman Owen Jr.

Pintoshine

<http://www.artisan-distiller.org>

Flake Stand bottom, and wall

12 Gallon Copper Pot

12 Gallon upsized by Husker

56.0" [1421.8mm]

36.0" [914.4mm]

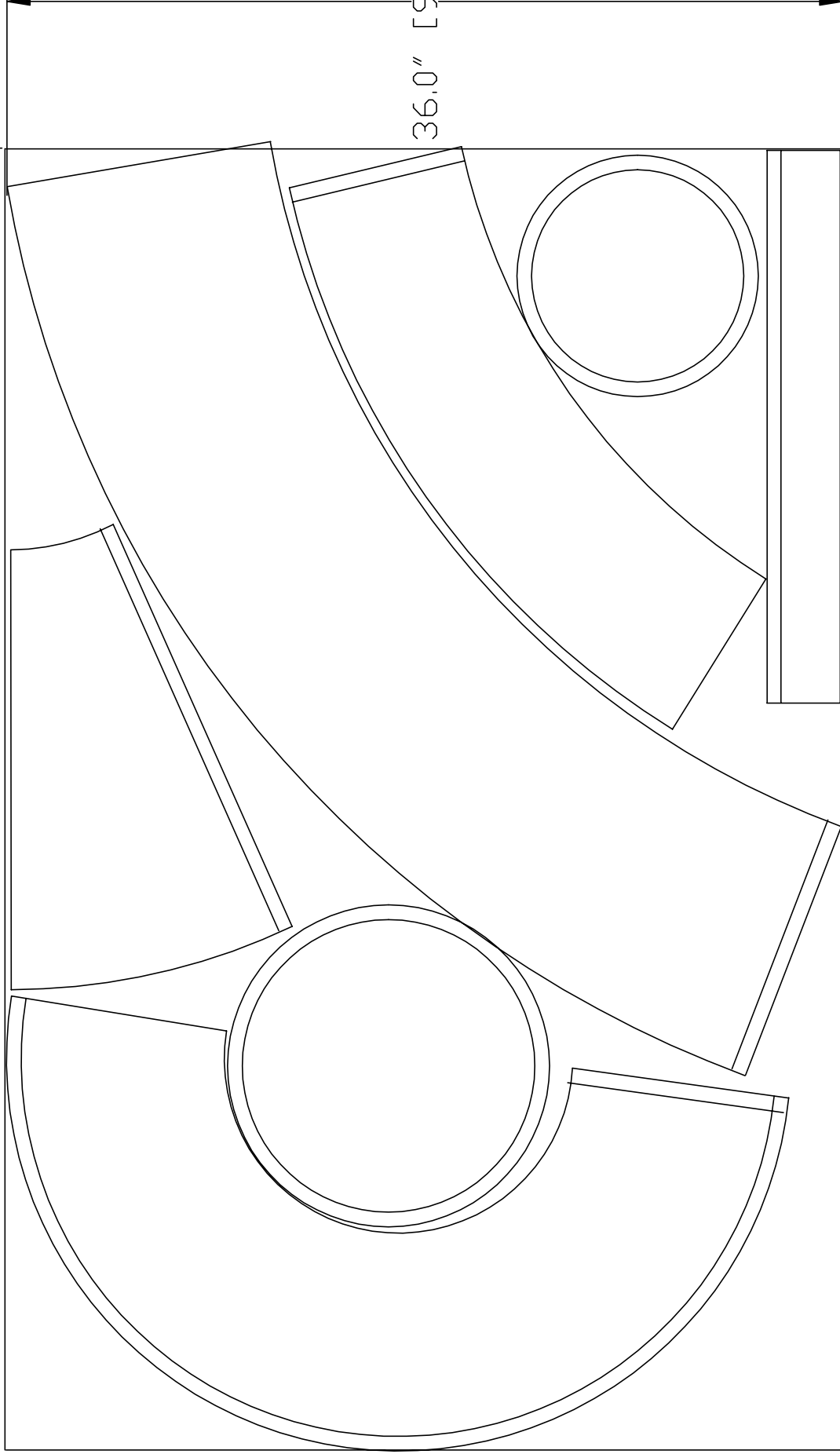

Sherman Owen Jr.  
Pintoshine  
<http://www.artisan-distiller.org>  
Suggested Layout of Pattern  
12 Gallon Copper Pot  
12 Gallon upsized by Husker

HowTo roll a lip in still's collar (or top of Flake Stand)

fold downward slowly with pliers

It may take several rounds



Flared outward with pliers

Hammer all the way round the perimeter each step.

Hammer here first

Then here

Then here

Be very careful to only hit the beaded edge.  
The sides dent easily.

Then hammer here carefully

Then here

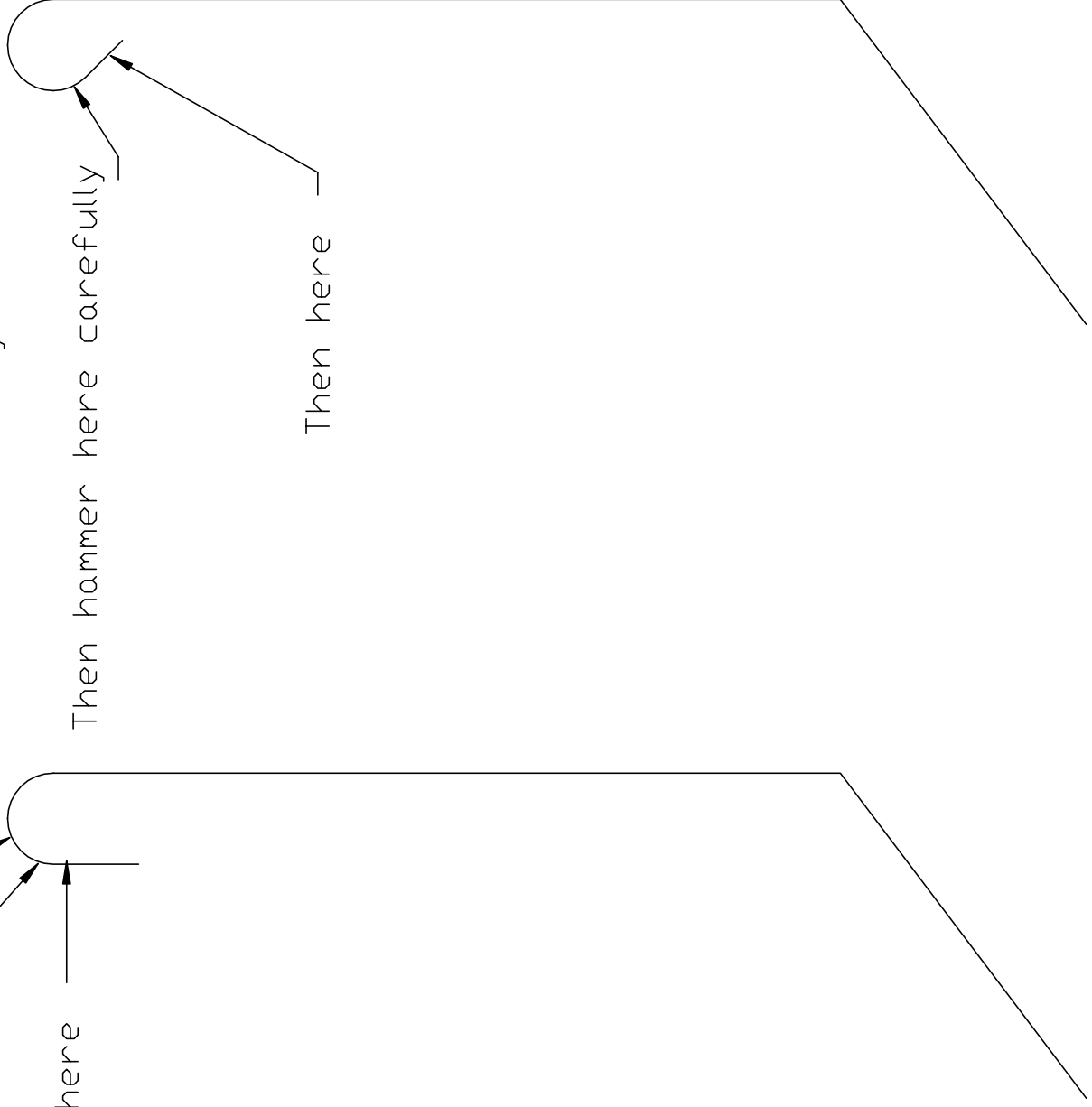



5gal Flake Stand  
(for 12g still)  
18x36" 0.025 thick

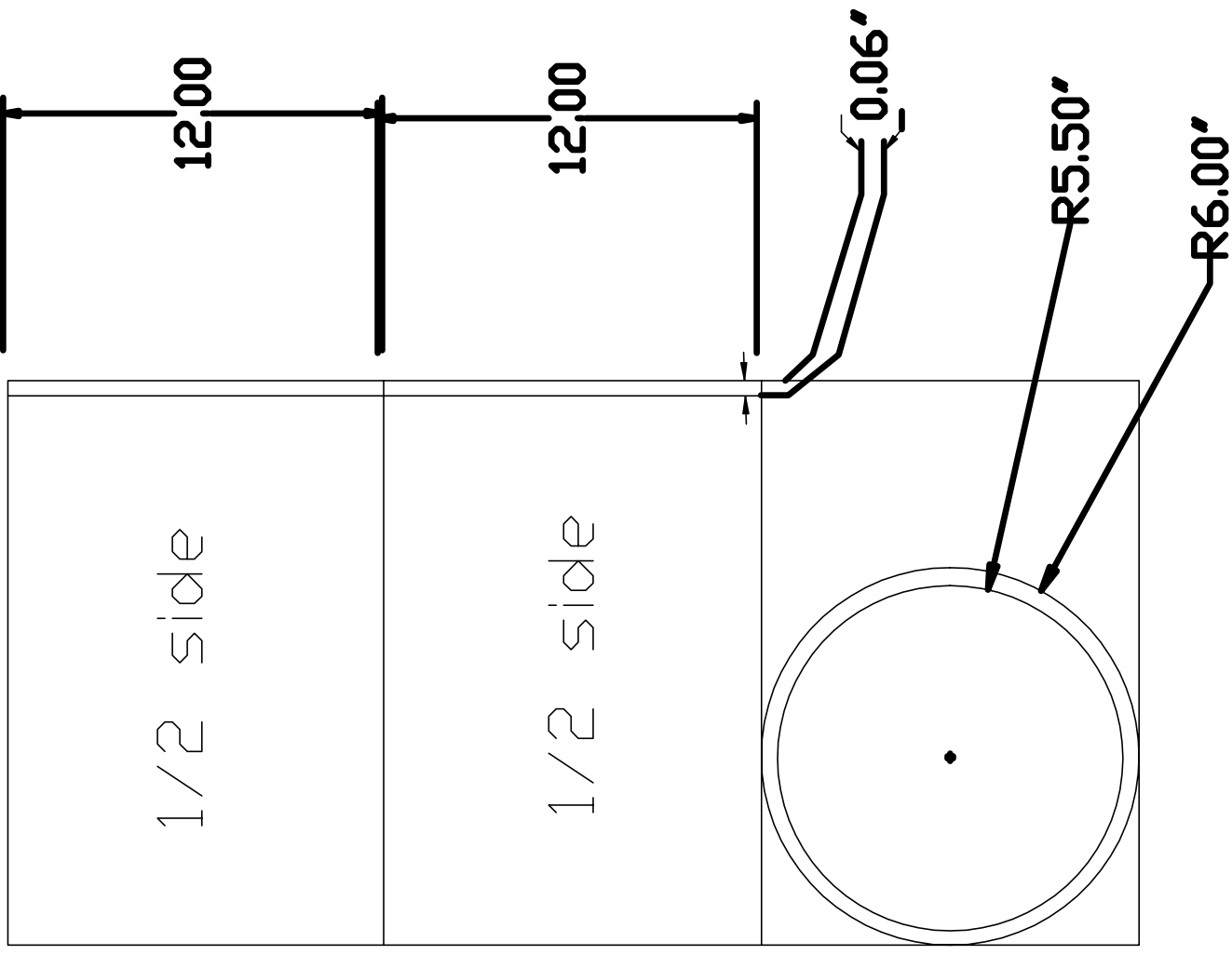

This is the layout for a 5 gallon Flake stand to go along with the 12 gallon still.

NOTE that the thickness of material is 0.025 and not 0.032 like the still.

Also, 2 flake stands can be made from a 5"x36" sheet, and 3 stands made from a 48"x36" sheet.

1	9	17	25
2	10	18	26
3	11	19	27
4	12	20	28
5	13	21	29
6	14	22	30
7	15	23	31
8	16	24	32

page 1

page 2

page 9

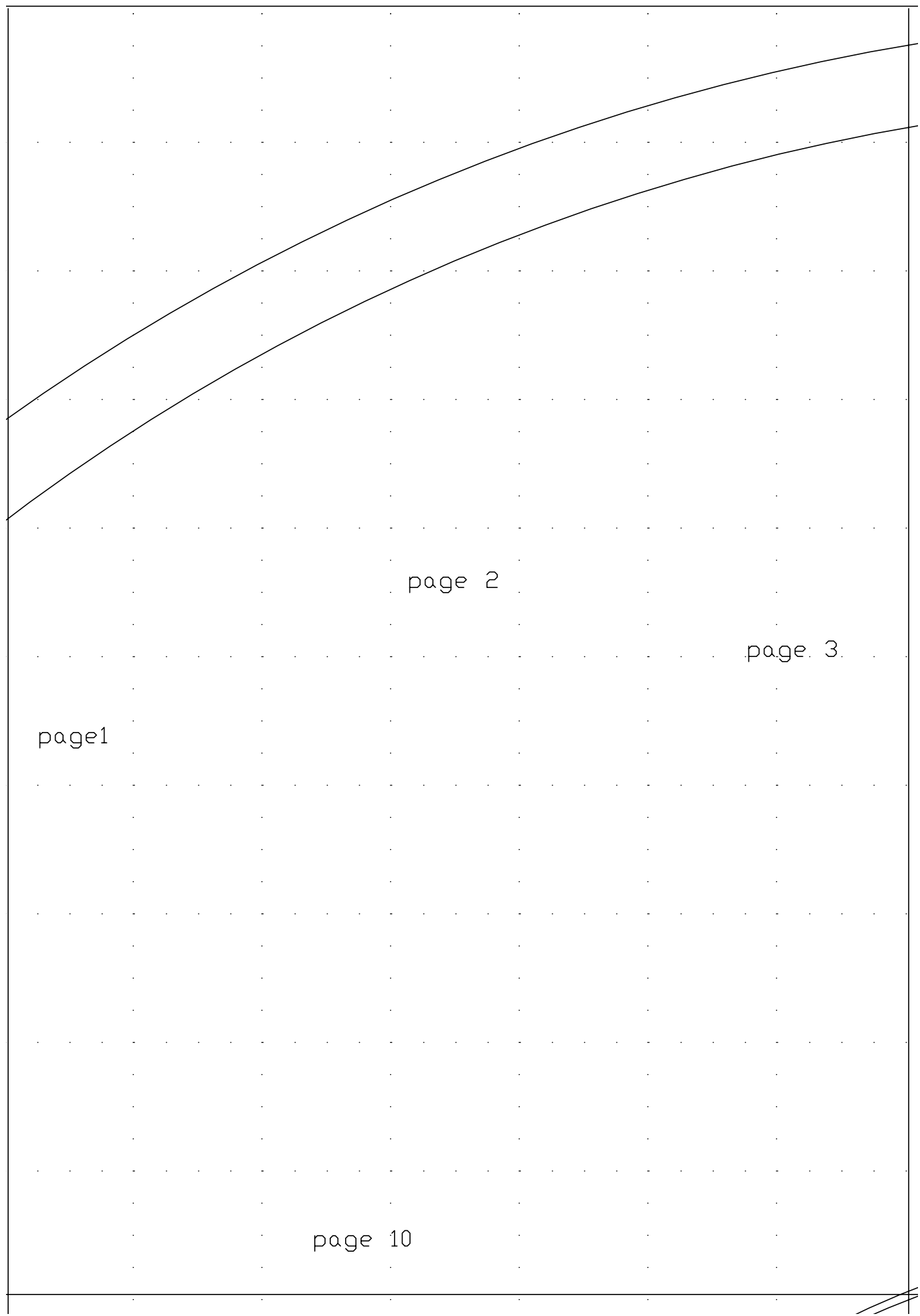

page1

page 2

page 3.

page 10

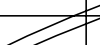

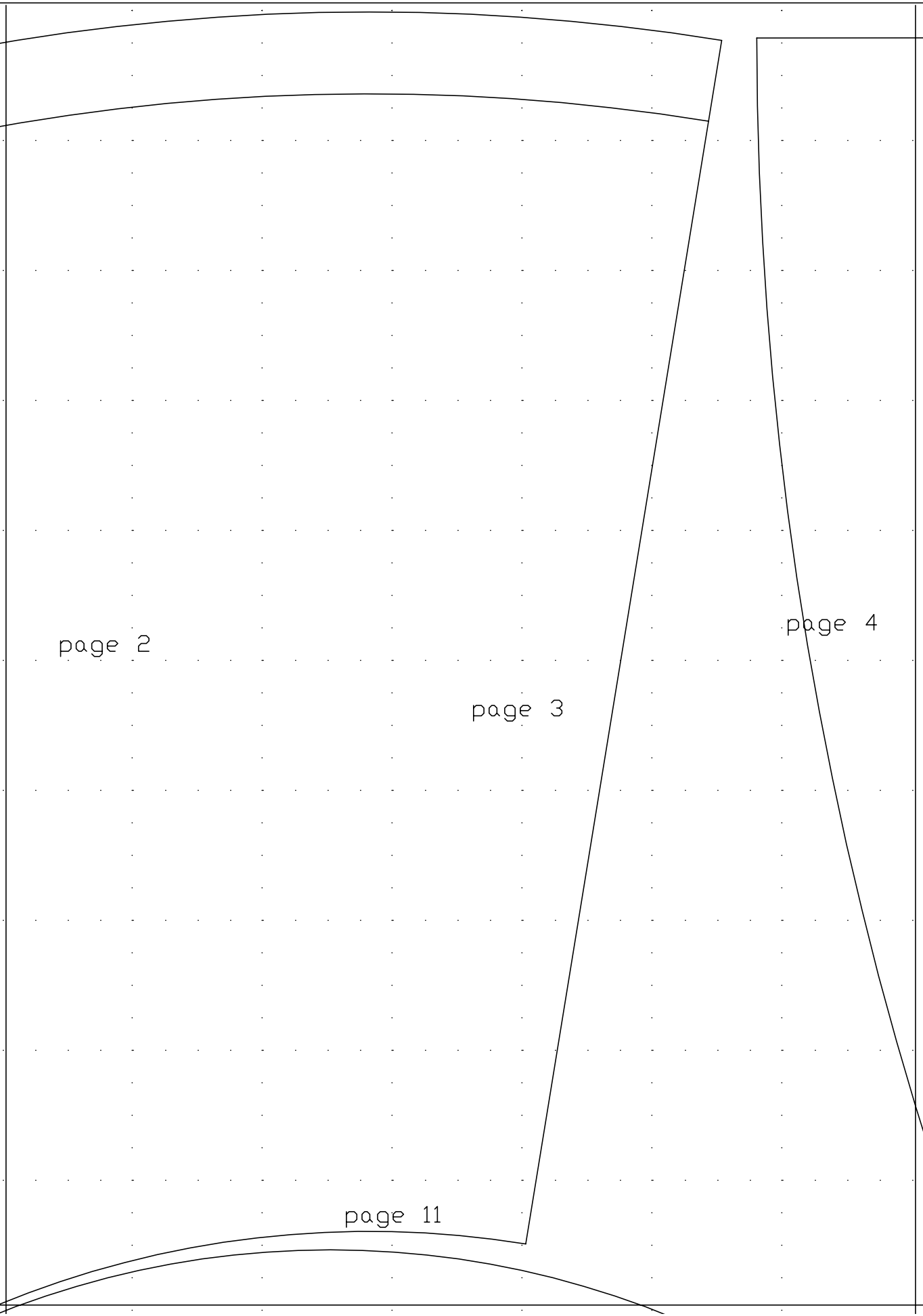

page 2

page 3

page 4

page 11

page 3

page 4

page 5

page 12

page 4

page 5

page 6

page 13

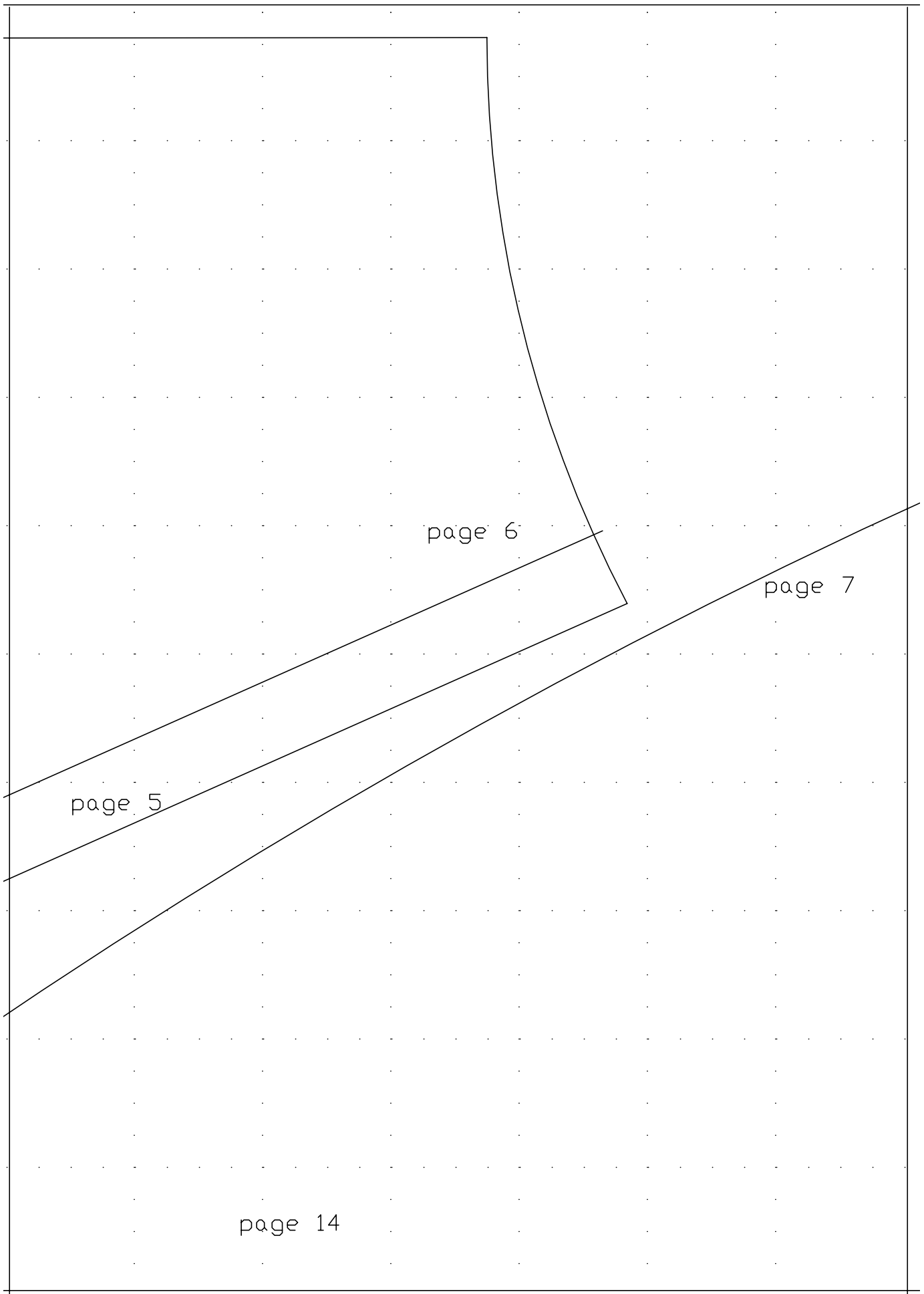

page 6

page 5

page 7

page 14



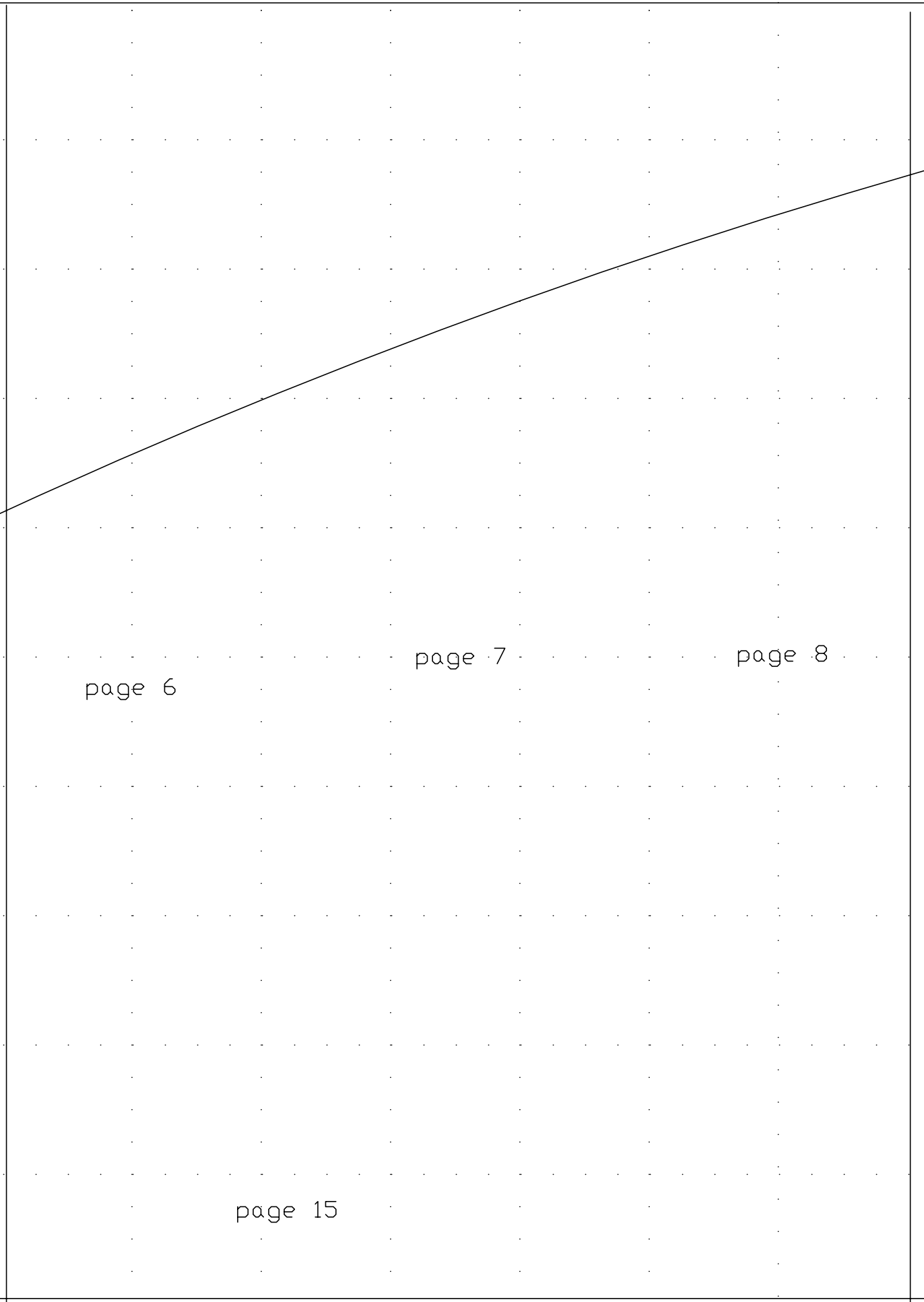

page 6

page 7

page 8

page 15

page 7

page 8

page 16

page 1

page 10

page 9

page 17

page 2

page 9

page 11

page 10

page 18

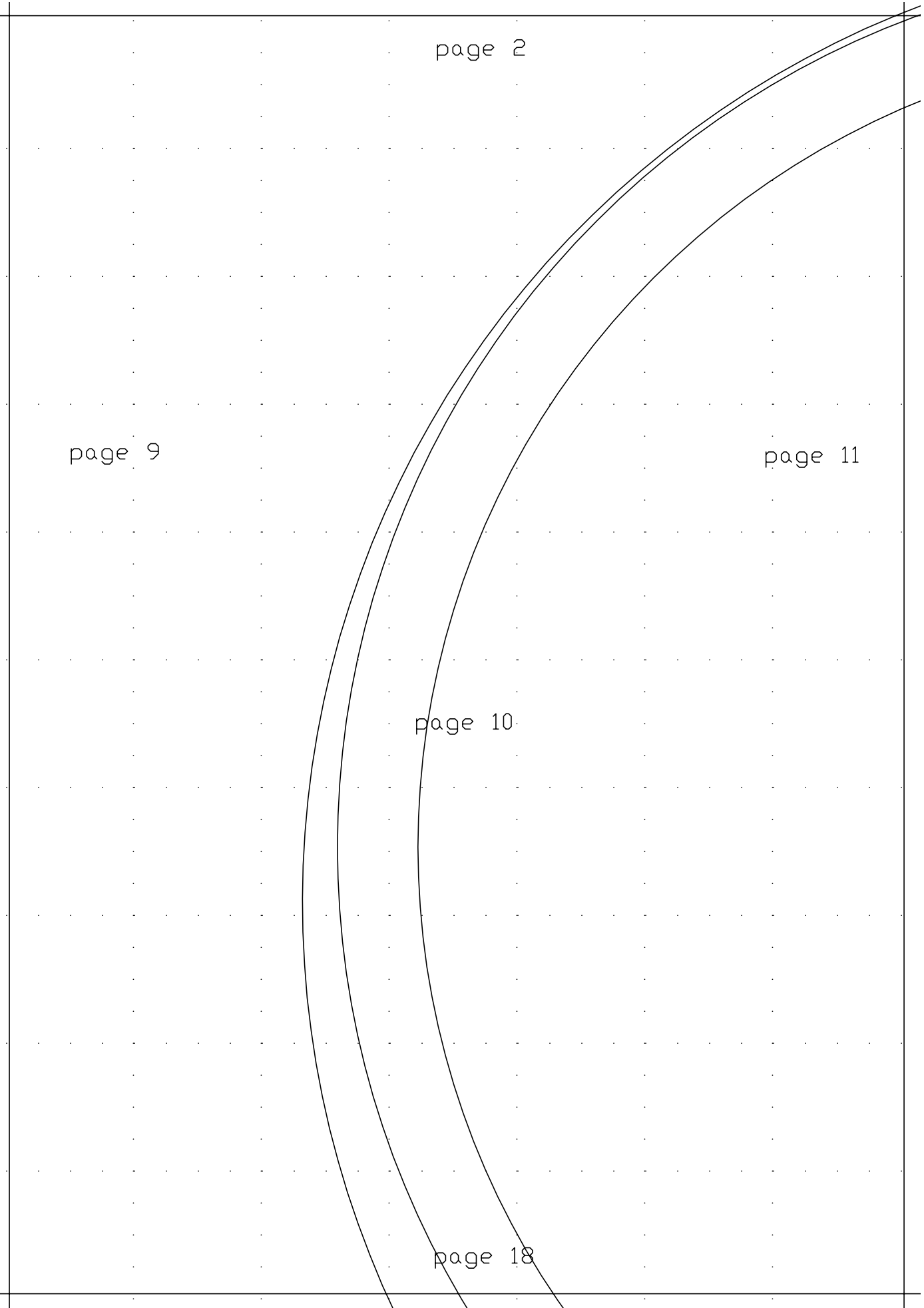

page 3

page 10

page 11

page 12

page 19

A grid with a horizontal top line and a horizontal bottom line. A diagonal line runs from the top-left towards the bottom-right. A curved line starts from the left edge and curves towards the bottom-right. A line starts from the top edge and goes down to the left edge. Another line starts from the top edge and goes down to the diagonal line. The labels 'page 4', 'page 11', 'page 12', 'page 13', and 'page 20' are placed in various regions of the grid.

page 4

page 12

page 13

page 11

page 20

page 5

page 14

page 12

page 13

page 21

page 6

page 15

page 13

page 14

page 22



page 7

page 14

page 15

page 16

page 23

page 8

page 15

page 16

page 24

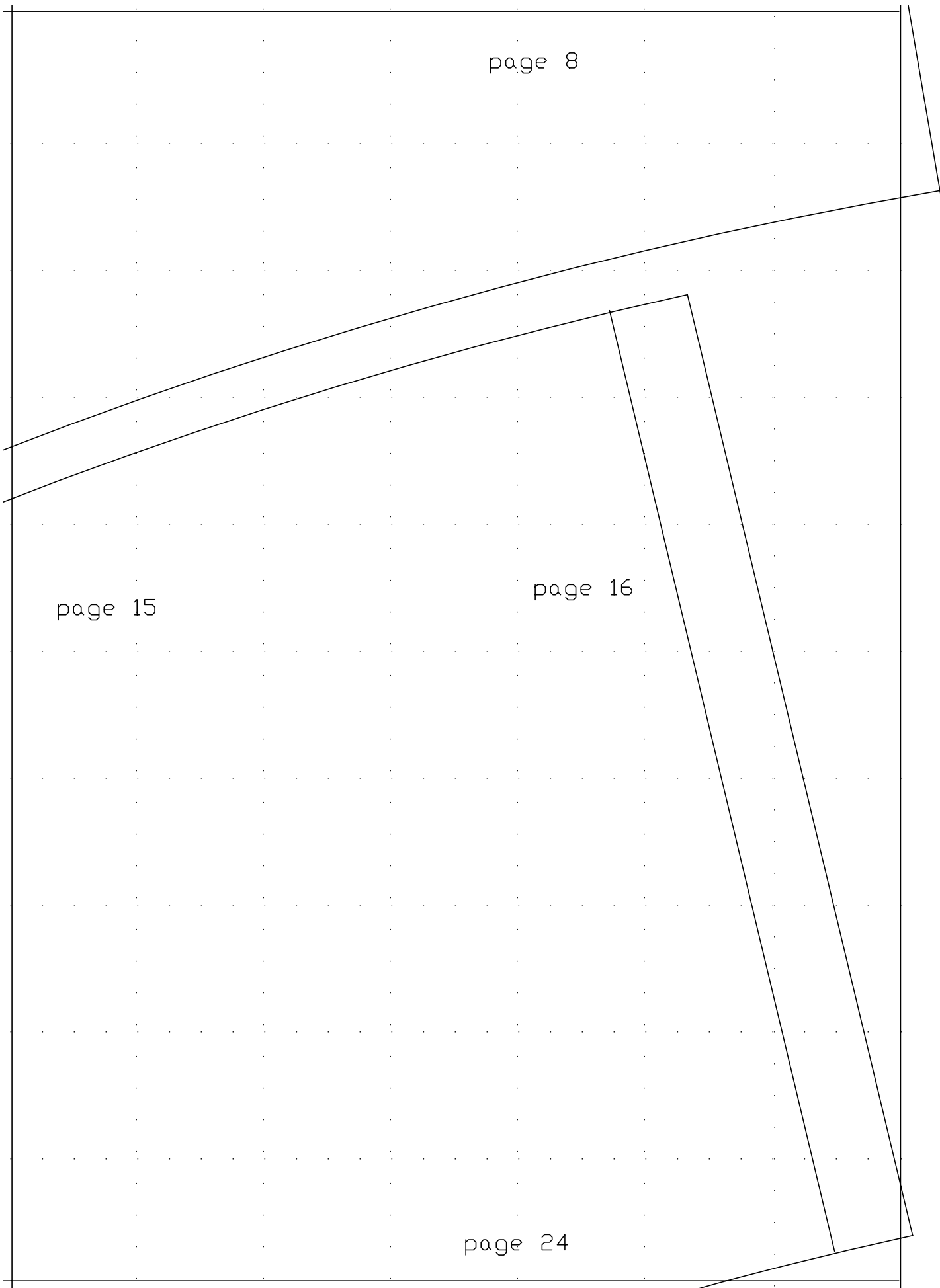

page 9

page 18

page 17

page 25

page 10

page 17

page 18

page 19

page 26

page 11

page 18

page 19

page 20

page 27

page 12

page 21

page 19

page 20

page 28

page 13

page 20

page 21

page 22

page 29

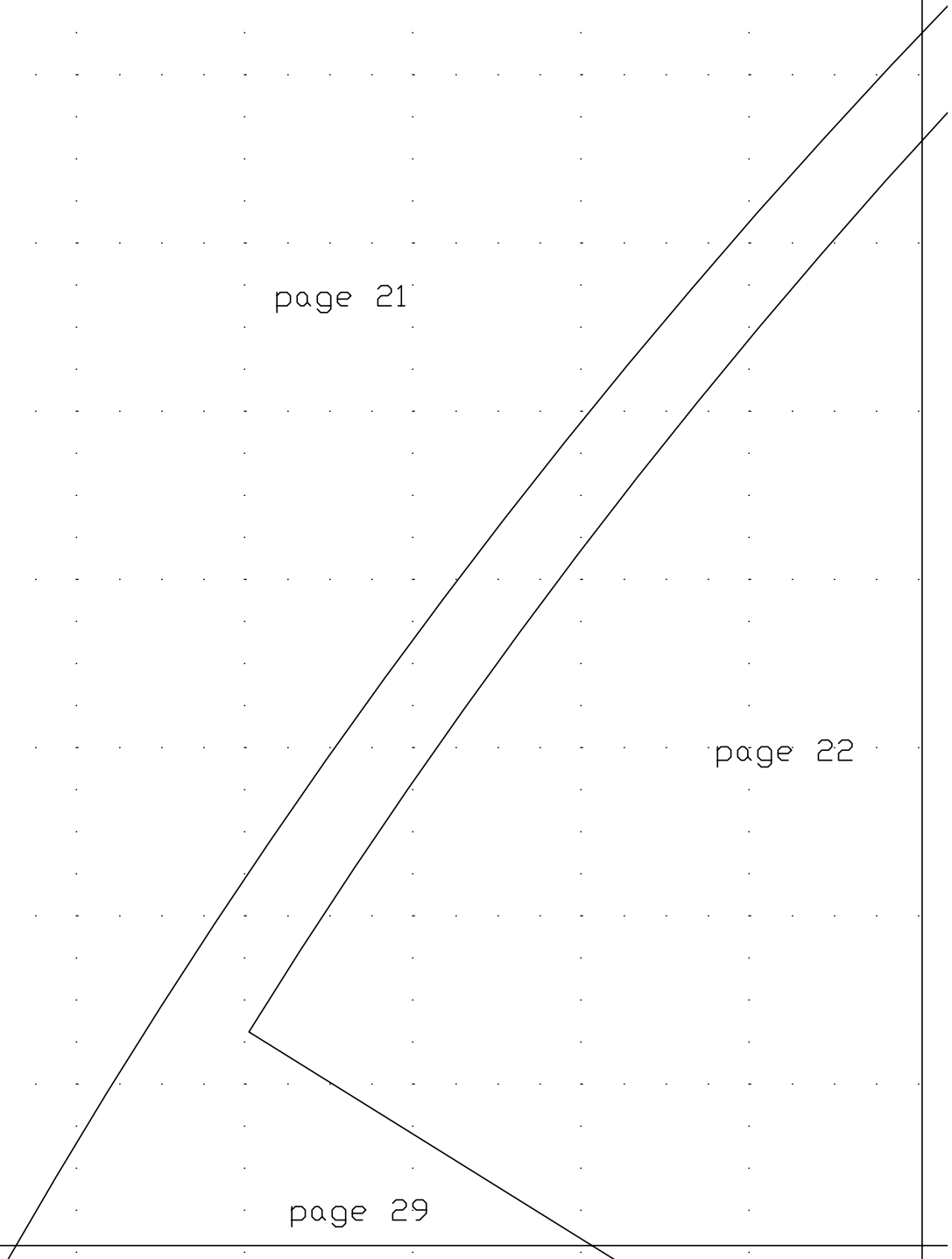

page 14

page 22

page 23

page 21

page 30



page 15

page 22

page 23

page 24

page 31

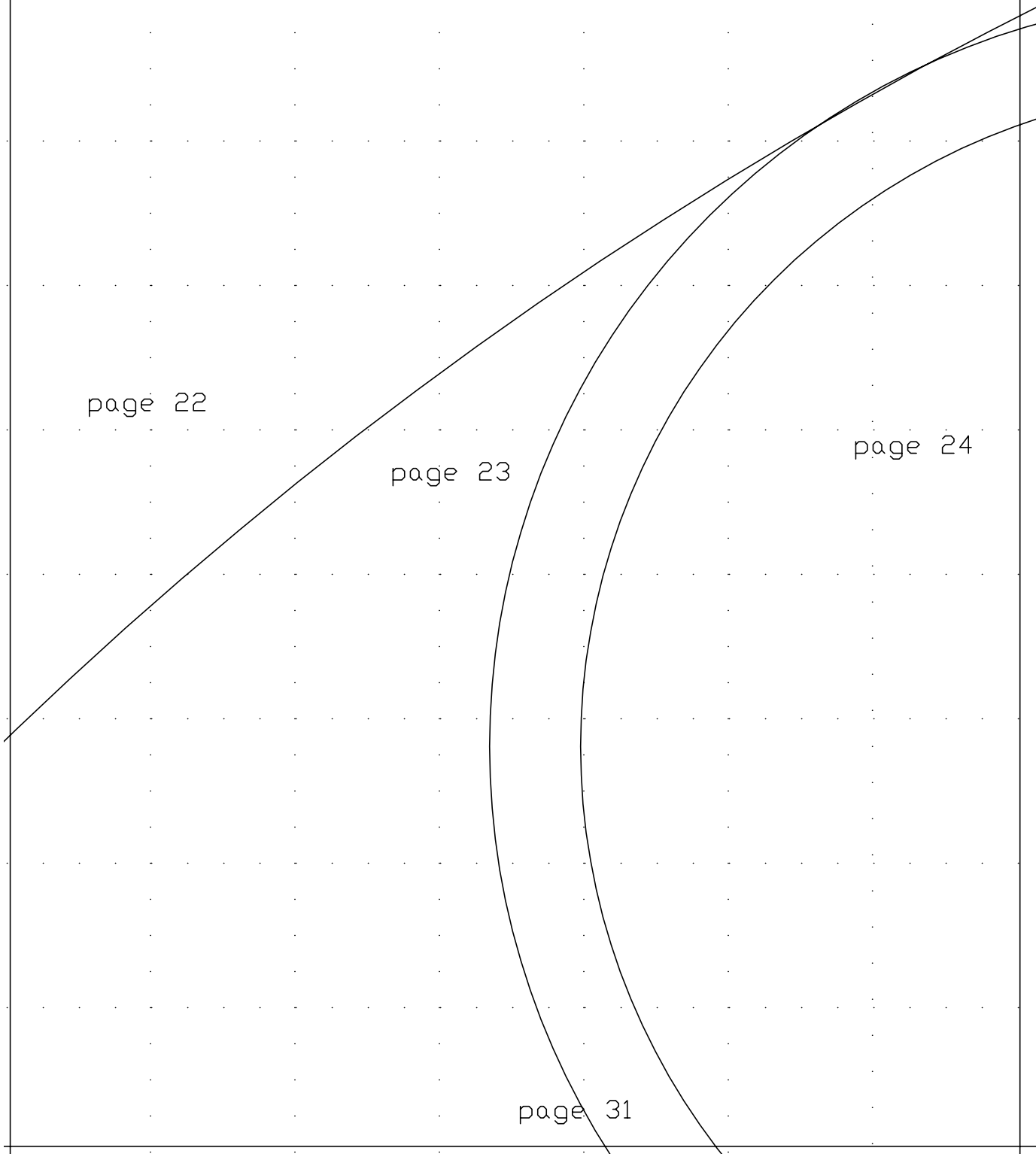

page 16

page 23

page 24

page 32

page 17

page 25

page 26

page 18

page 25

page 26

page 27

page 19

page 27

page 28

page 26

page 20

page 28

page 29

page 27

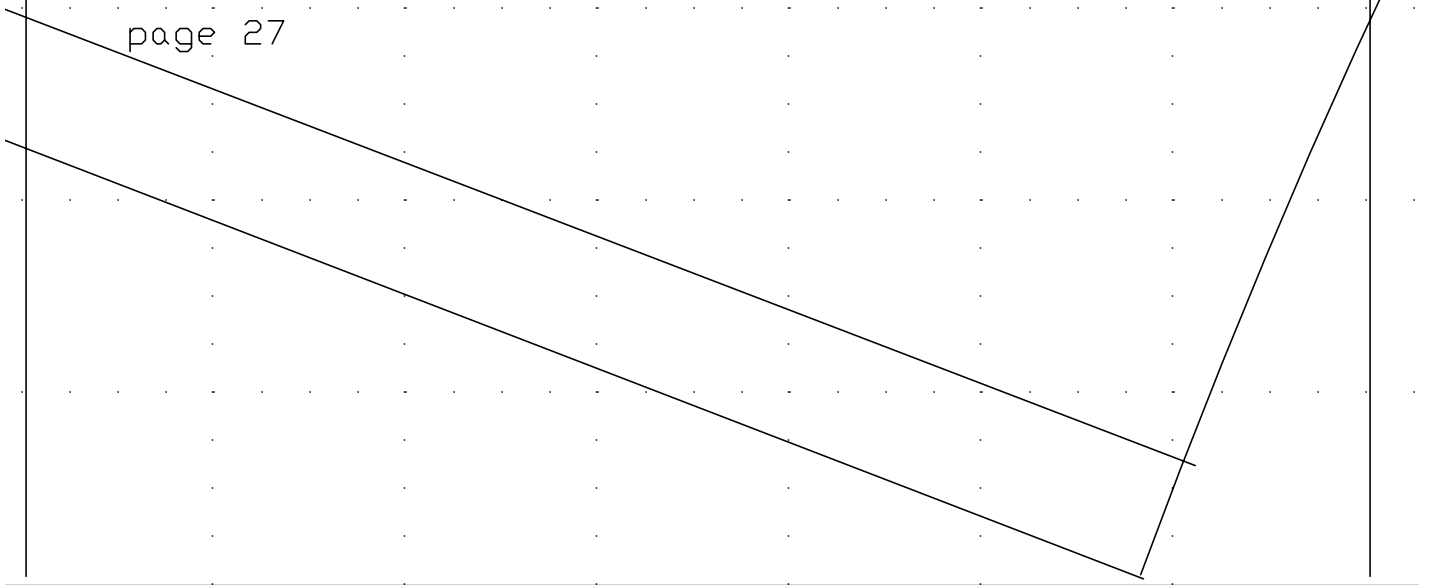

page 21

page 28

page 29

page 30

page 22

page 29

page 30

page 31



page 23

page 30

page 31

page 32

page 24

page 31

page 32